

#	BEARING TYPE
BEA. 1	Full complement cylindrical roller bearings NCF18 series
BEA. 2	Full complement cylindrical roller bearings NCF18 series
BEA. 3	Paired set cylindrical roller bearings RN series
BEA. 4	Paired set cylindrical roller bearings RN series
BEA. 5	Spherical roller bearings
BEA. 6	Spherical roller bearings
BEA. 7	Single-row cylindrical roller bearings NJ series
BEA. 8	Single-row cylindrical roller bearings NJ series
BEA. 9	Single-row cylindrical roller bearings NU series
BEA. 10	Single-row taper roller bearings
BEA. 11	Single-row taper roller bearings



Main bearings:  
T3 Segment - Technological bearings



**Project 'Wind Mill'**  
**Wind multipliers**



#	BEARING TYPE
BEA. 1	Full complement cylindrical roller bearings NCF18 series
BEA. 2	Full complement cylindrical roller bearings NCF18 series
BEA. 3	Paired set cylindrical roller bearings RN series
BEA. 4	Paired set cylindrical roller bearings RN series
BEA. 5	Spherical roller bearings
BEA. 6	Spherical roller bearings
BEA. 7	Single-row cylindrical roller bearings NJ series
BEA. 8	Single-row cylindrical roller bearings NJ series
BEA. 9	Single-row cylindrical roller bearings NU series
BEA. 10	Single-row taper roller bearings
BEA. 11	Single-row taper roller bearings

Technological bearings for speed multipliers used in medium and high power wind turbines (over 850 kW)

Maximum reliability required due to the application conditions

Bearings optimization through RKB R&D activity

Main bearings:  
T3 Segment - Technological bearings



**Project 'Wind-Mill'**  
Wind multipliers





# Main bearings: T3 Segment - Technological bearings

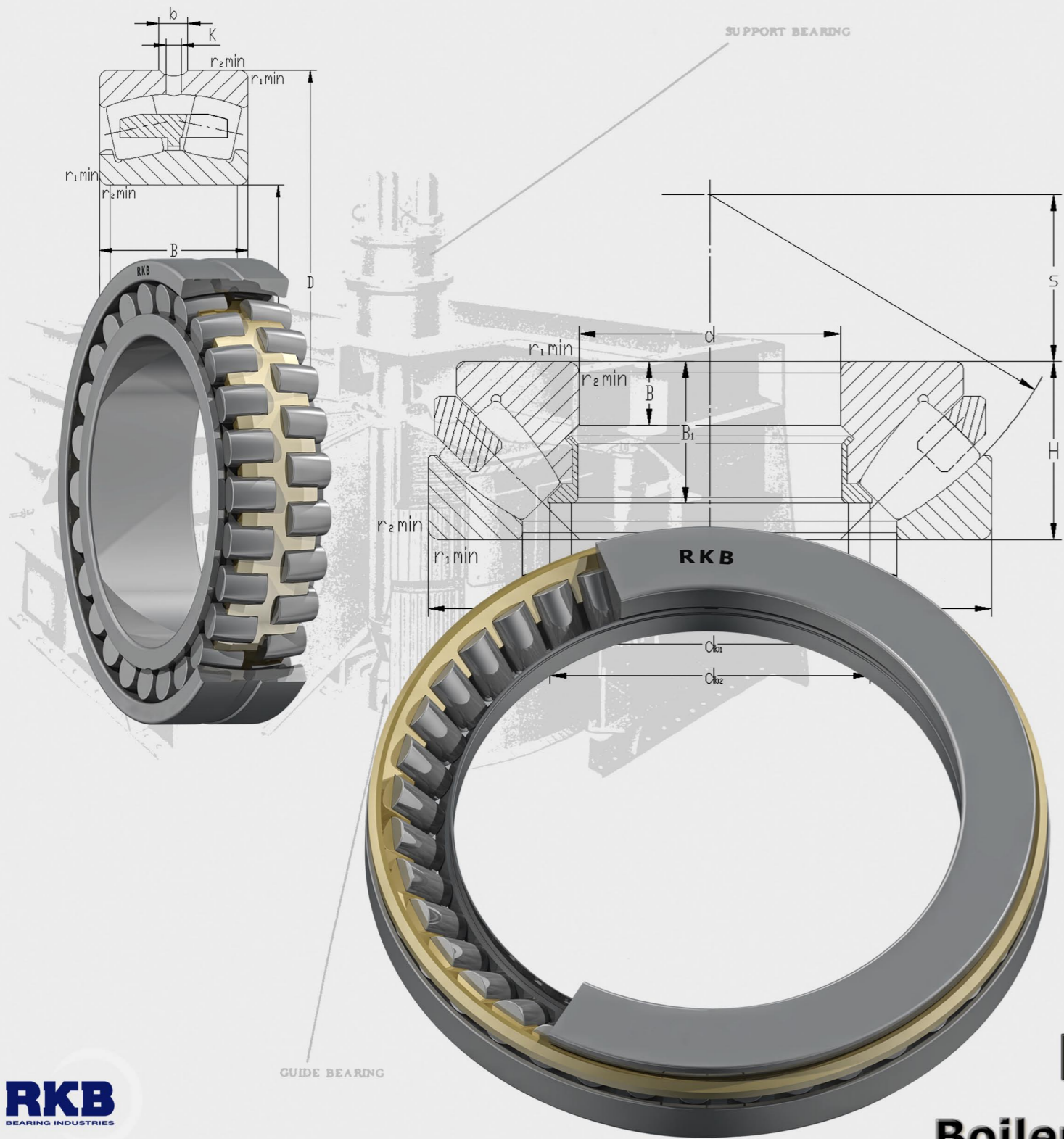

Combustion Air  
(to boiler)  
620°F

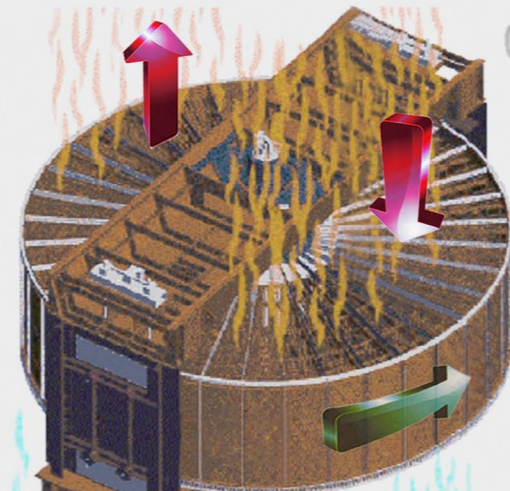

Flue Gas  
(from boiler)  
700°F

Inlet Air  
100°F

to stack  
290°F

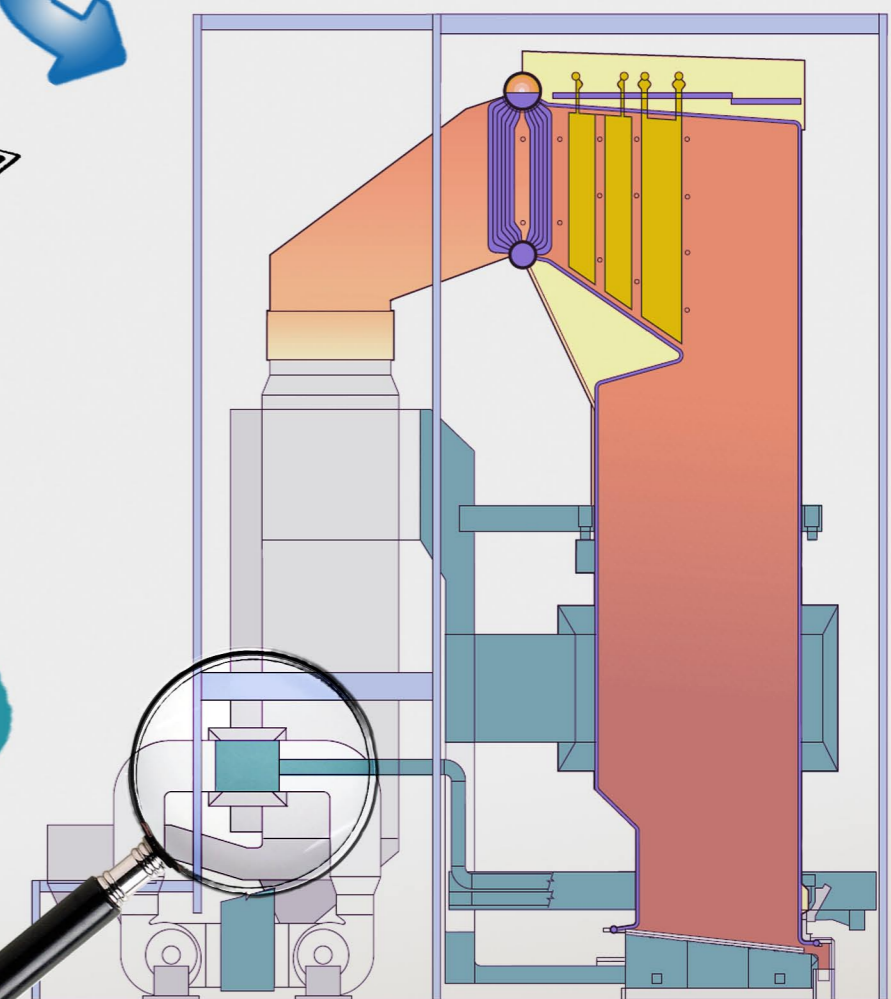
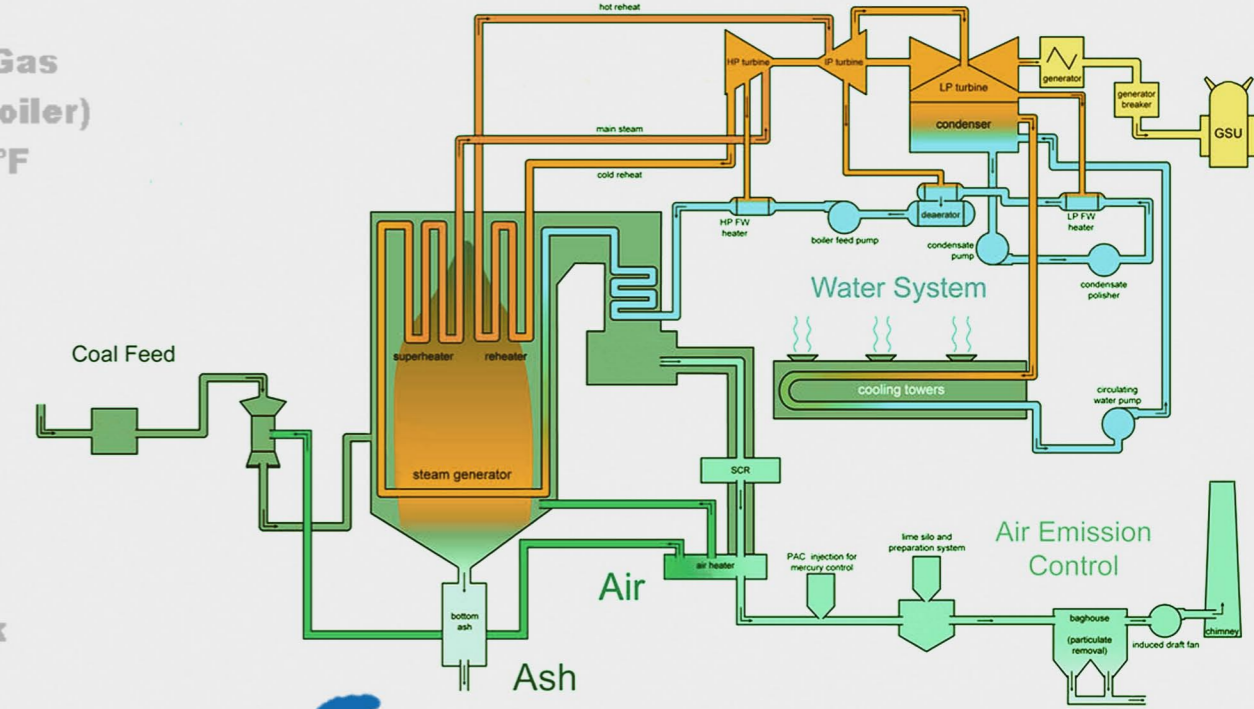
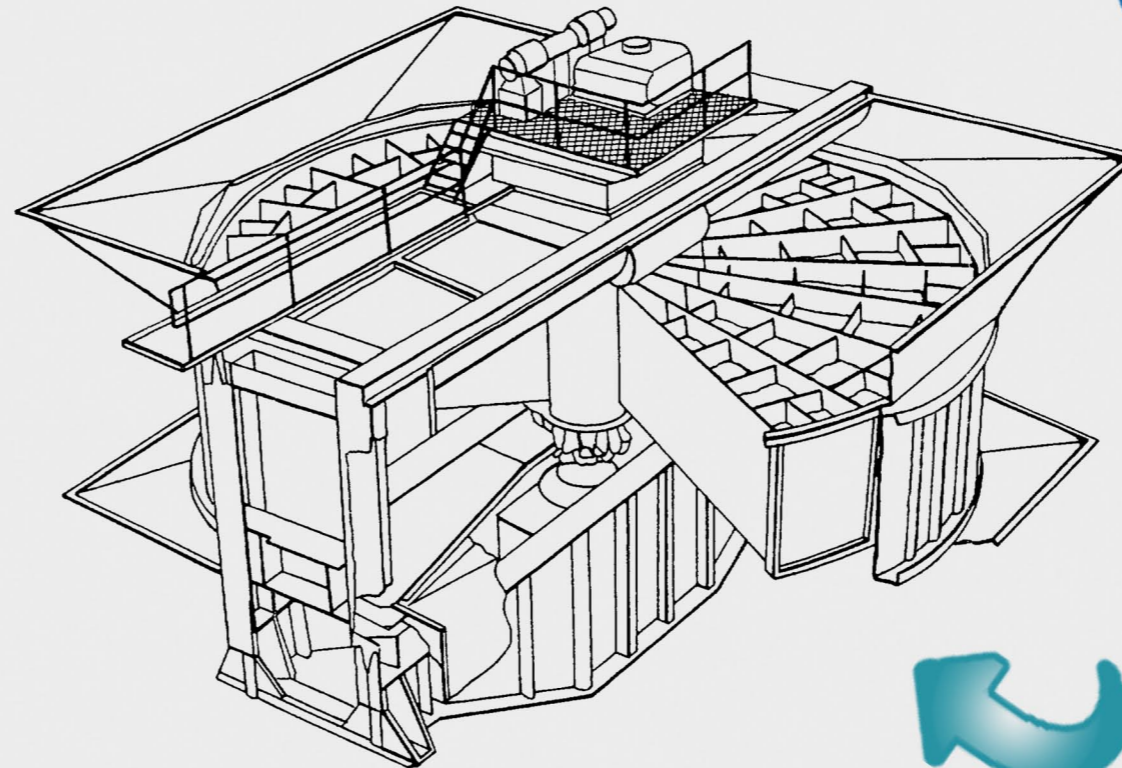

## Project 'ABI' Boiler for power generation

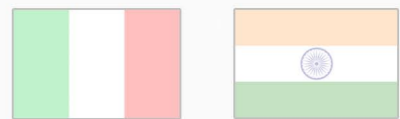

# Main bearings: T3 Segment - Technological bearings

Technological spherical roller thrust bearings and spherical roller bearings for vertical rotor of bi-drum boiler regenerative air preheater

Up to 950 mm inner diameter and bearing unit mass exceeding 2950 kg

Optimized execution for heavy loads at low rotational speeds (3-5 rpm)

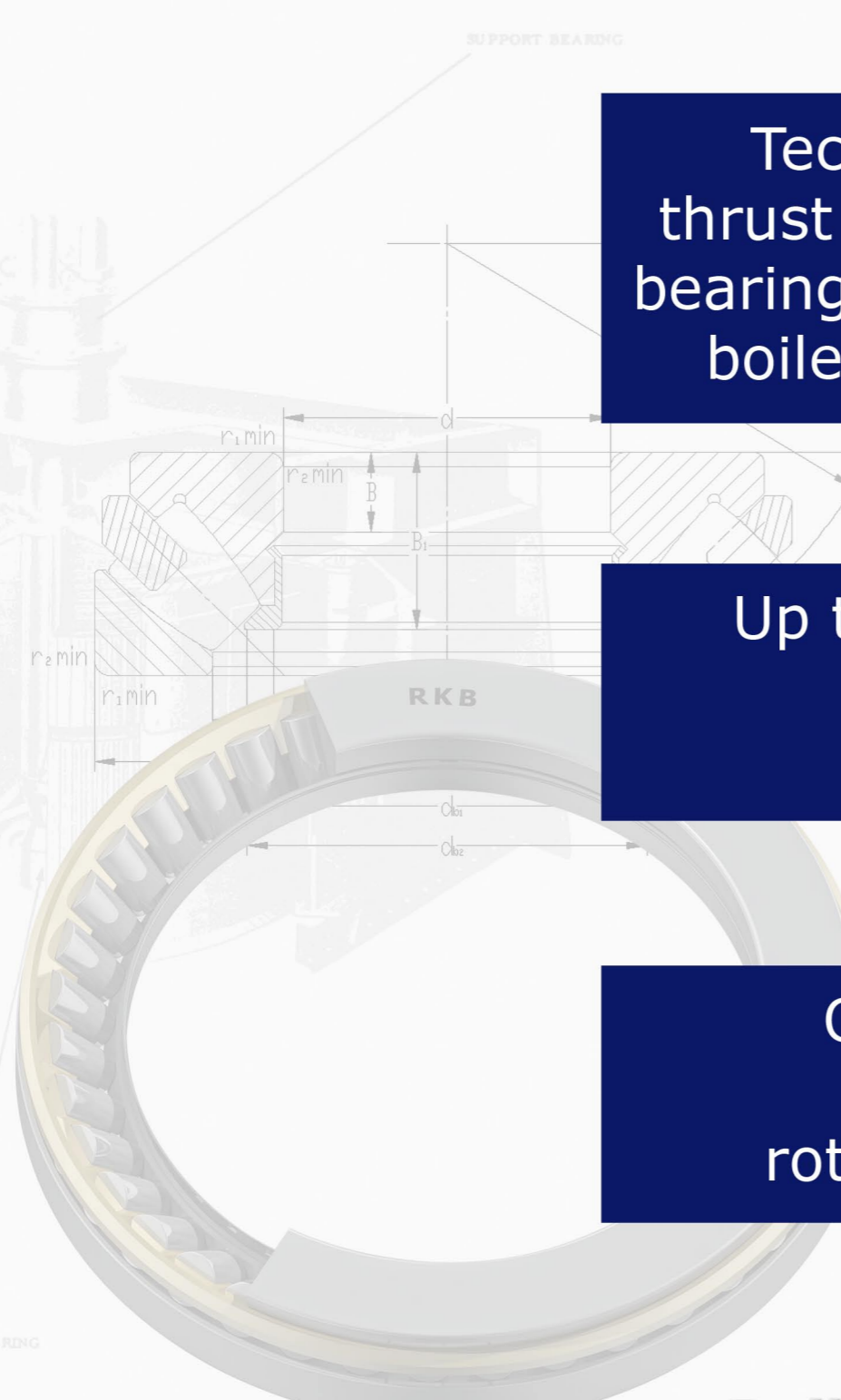
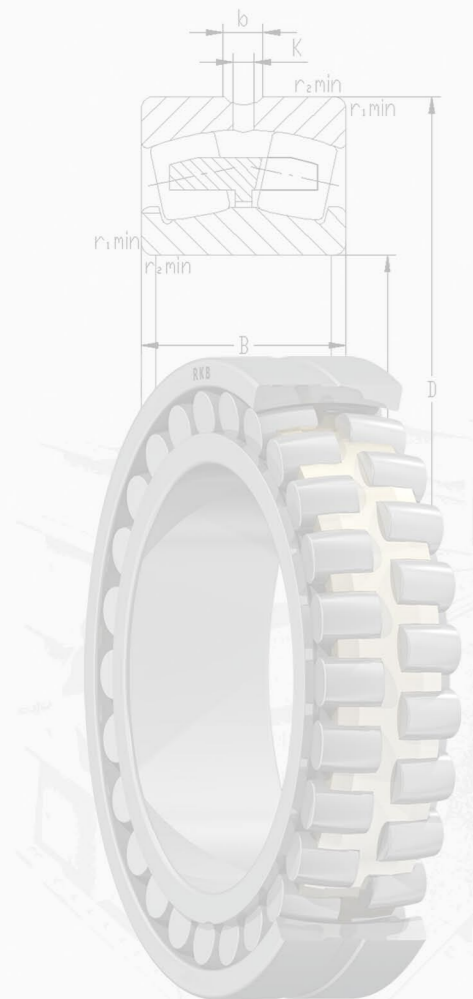

Combustion Air (to boiler) 620°F  
Flue Gas (from boiler) 700°F

100°F 290°F

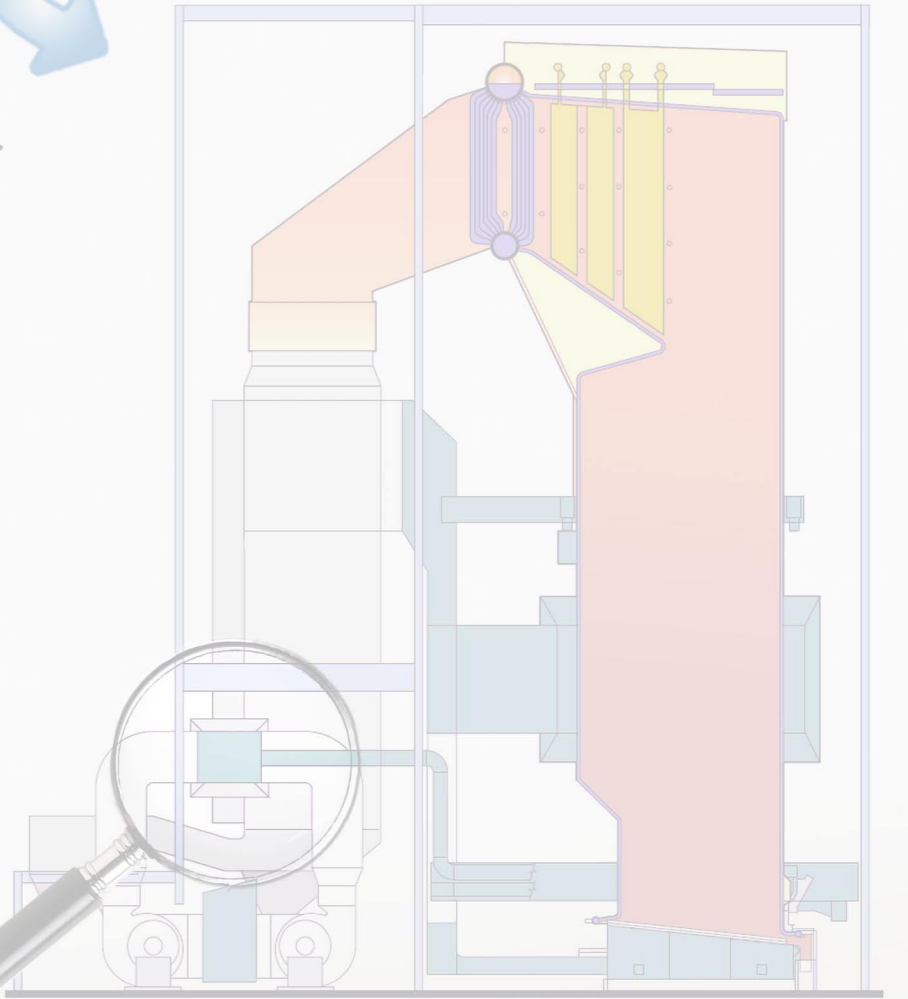
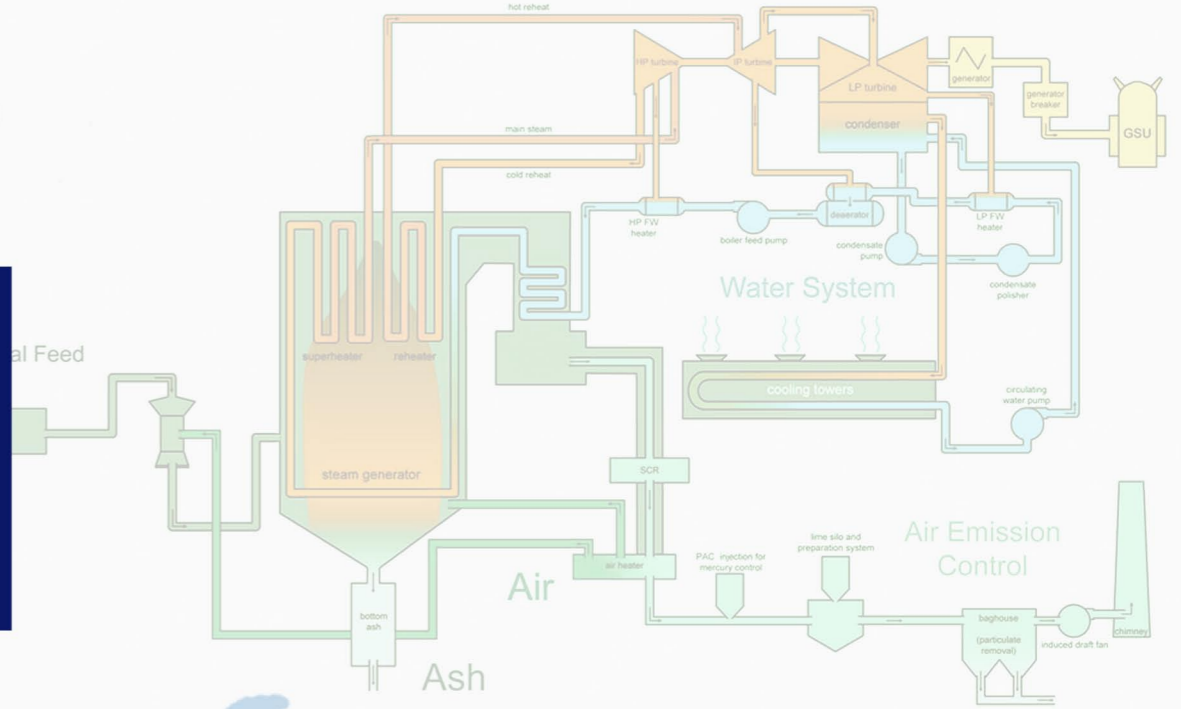

## Project 'ABI' Boiler for power generation